

P5010 ES



- ▶ P5010 multistage ejector with Pi, Si or Xi COAX® push-in cartridge.
- ▶ Integrated air-saving function (ES) that minimises the air consumption by controlling the incoming air flow to the pump.
- ▶ Operates on a roughly similar system to that of a thermostat in a heating system.
- ▶ Large hysteresis is recommended for sealed vacuum handling applications such as metal sheet, glass or plastic handling.
- ▶ Small hysteresis is recommended if a very accurate vacuum level has to be maintained in the process.
- ▶ Adjustable ES switch level.
- ▶ Pneumatic function.
- ▶ Configurable and modular design.
- ▶ Separate port with built-in blow-off check valve. High flow capacity to maximize efficiency to release an object.

Technical data

Description	Unit	Value
Feed pressure, max.	MPa	0.7
Feed pressure, minimum to break away for blow-off	MPa	0.4*
Noise level	dBA	68-71
Material		NBR, PA, AI, SS, POM, CuZn
Temperature range	°C	0-60
Weight	g	640-890
Signal range	-kPa	15-99
Function		2/2 NO
Flow, blow-off at 0.6 MPa	NI/s	7.5

*For Pi cartridge(s) - do not use common feed pressure for pump and blow-off.

Technical data, specific

Description	Unit	Value	
		ES small hysteresis	ES large hysteresis
Hysteresis	kPa	1-6	5-10

Performance tables

Depending upon choice of COAX® cartridge, applicable performance data of the P5010 ES can be found in the tables for vacuum flow and evacuation time for models P5010 Pi, Si and Xi.

Function

A vacuum-controlled valve shuts off the flow of compressed air to the pump when the pre-set vacuum level is reached (1). The vacuum level is set by a knob. Because of minor leakage in a vacuum system the vacuum level drops, and after a while the start-up level of the valve is reached (2). Then the pump will start and work until the shut-off level is reached again (3), etc.

Connection for ES function*

- A = Vacuum pump with non-return valve
- B = Vacuum switch
- C = Feed valve
- D = Suction cup
- E = Vacuum filter

*Connection for blow-off found with dimensional drawing below.

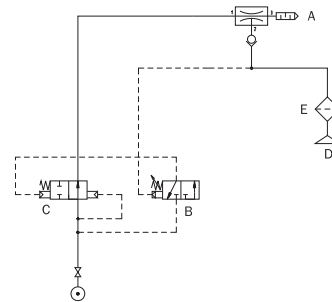
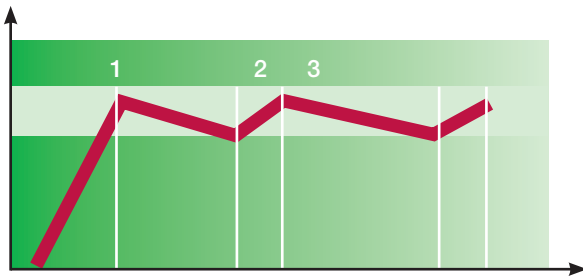

Ordering information

1. Select Housing		P5010 code
Housing, connection Ø 10 mm		00
Housing, connection Ø 3/8"		01

2. COAX® push-in modules		P5010 Code
d	COAX® push-in module Pi48-2X1, non-return valve	AK
c	COAX® push-in module Pi48-3X1, non-return valve	AL
d	COAX® push-in module Pi48-2X2, non-return valve	AO
c	COAX® push-in module Pi48-3X2, non-return valve	AP
d	COAX® push-in module Si32-2X1, non-return valve	AC
c	COAX® push-in module Si32-3X1, non-return valve	AD
d	COAX® push-in module Si32-2X2, non-return valve	AG
c	COAX® push-in module Si32-3X2, non-return valve	AH
d	COAX® push-in module Xi40-2X1, non-return valve	AS
c	COAX® push-in module Xi40-3X1, non-return valve	AT
d	COAX® push-in module Xi40-2X2, non-return valve	AW
c	COAX® push-in module Xi40-3X2, non-return valve	AX

3. Function		P5010 Code
Function P5010 ES 2/2 NO large hysteresis		11
Function P5010 ES 2/2 NO small hysteresis		12

Example	Ordering number
Housing, connection Ø 10 mm Pi48-2X1, non-return valve, Function P5010 ES 2/2 NO small hysteresis	P5010 00 AK 12

