

P5010



- ▶ New patented COAX® push-in technology allows insertion and removal of the cartridge without tools.
- ▶ Available with a two or three-stage COAX® cartridge MIDI. Choose an Si cartridge for extra vacuum flow, a Pi cartridge for high performance at low feed pressure or an Xi cartridge when high flow and deep vacuum is needed.
- ▶ Integrated flow-through silencer that is unaffected by dust and dirt.
- ▶ Substantially lower air-consumption as compared to conventional ejectors of similar sizes.
- ▶ Slim, compact, configurable and modular design.
- ▶ Low weight.

Technical data

Description	Unit	Value
Feed pressure, max	MPa	0.7
Noise level *)	dBA	68–70
Temperature range	°C	-10–80
Weight	g	230–600
Material		AL, CuZn, NBR, PA, SS, PE

*) At vacuum level 40 -kPa and feed pressure 0.3 MPa.

Vacuum flow

COAX® cartridge	Feed pressure MPa	Air consumption NI/s	Vacuum flow (NI/s) at different vacuum levels (-kPa)										Max vacuum -kPa
			0	10	20	30	40	50	60	70	80	90	
Pi48-2	0.30	2.0	5.6	2.5	1.8	1.1	0.65	0.50	0.35	0.25	0.10	—	90
Pi48-3	0.30	2.0	5.6	2.5	1.8	1.1	0.65	0.50	0.35	0.25	0.10	—	90
Si32-2	0.60	1.75	3.3	3.0	2.6	1.7	0.90	0.60	0.50	0.35	—	—	75
Si32-3	0.60	1.75	6.0	3.5	2.6	1.7	0.90	0.60	0.50	0.35	—	—	75
Xi40-2	0.45	1.83	2.8	2.3	1.6	1.0	0.73	0.58	0.43	0.32	0.18	0.03	95
Xi40-3	0.45	1.83	5.9	3.0	2.0	1.3	0.73	0.58	0.43	0.32	0.18	0.03	95

For vacuum flows at other feed pressures, see section Vacuum cartridges/integration.

Evacuation time

COAX® cartridge	Feed pressure MPa	Air consumption NI/s	Evacuation time (s/l) to reach different vacuum levels (-kPa)									Max vacuum -kPa
			10	20	30	40	50	60	70	80	90	
Pi48-2	0.30	2.0	0.030	0.070	0.13	0.26	0.46	0.70	1.0	1.6	4.0	90
Pi48-3	0.30	2.0	0.020	0.060	0.12	0.25	0.45	0.70	1.0	1.6	4.0	90
Si32-2	0.60	1.75	0.030	0.070	0.10	0.18	0.33	0.53	0.80	—	—	75
Si32-3	0.60	1.75	0.020	0.050	0.10	0.18	0.33	0.53	0.80	—	—	75
Xi40-2	0.45	1.83	0.04	0.09	0.17	0.28	0.44	0.63	0.90	1.3	2.3	95
Xi40-3	0.45	1.83	0.022	0.062	0.12	0.22	0.37	0.57	0.84	1.2	2.2	95

For evacuation times at other feed pressures, see section Vacuum cartridges/integration.

Blow flow

COAX® cartridge	Feed pressure MPa	Air consumption NI/s	Blow flow (NI/s) at different pressure levels (kPa)												Max pressure kPa
			0	20	40	60	70	80	90	100	110	120	130	140	
Pi48-2	0.6	3.5	6.15	6.15	5.95	5.03	4.49	4.49	4.49	4.49	4.49	4.26	4.0	3.63	140
Pi48-3	0.6	3.55	9.5	6.5	6.0	5.3	4.7	4.6	4.6	4.5	4.5	4.3	4.0	3.7	140
Si32-2	0.6	1.75	5.05	4.25	3.30	2.65	2.35	1.8	—	—	—	—	—	—	70
Si32-3	0.6	1.75	7.8	4.6	3.3	2.7	2.3	1.8	—	—	—	—	—	—	70
Xi40-2	0.6	2.33	5.1	4.6	3.4	3.3	3.1	2.8	2.4	—	—	—	—	—	90
Xi40-3	0.6	2.33	8.4	5.1	3.92	3.39	3.23	2.95	2.58	—	—	—	—	—	90

For performance graphs, see section Vacuum cartridges/integration.

Ordering information

1. Select Housing		P5010 code
Housing, connection Ø 10 mm		00
Housing, connection Ø 3/8"		01

2. COAX® push-in modules		P5010 Code
b	COAX® push-in module Pi48-2X1	AI
a	COAX® push-in module Pi48-3X1	AJ
d	COAX® push-in module Pi48-2X1, non-return valve	AK
c	COAX® push-in module Pi48-3X1, non-return valve	AL
b	COAX® push-in module Pi48-2X2	AM
a	COAX® push-in module Pi48-3X2	AN
d	COAX® push-in module Pi48-2X2, non-return valve	AO
c	COAX® push-in module Pi48-3X2, non-return valve	AP
b	COAX® push-in module Si32-2X1	AA
a	COAX® push-in module Si32-3X1	AB
d	COAX® push-in module Si32-2X1, non-return valve	AC
c	COAX® push-in module Si32-3X1, non-return valve	AD
b	COAX® push-in module Si32-2X2	AE
a	COAX® push-in module Si32-3X2	AF
d	COAX® push-in module Si32-2X2, non-return valve	AG
c	COAX® push-in module Si32-3X2, non-return valve	AH
b	COAX® push-in module Xi40-2X1	AQ
a	COAX® push-in module Xi40-3X1	AR
d	COAX® push-in module Xi40-2X1, non-return valve	AS
c	COAX® push-in module Xi40-3X1, non-return valve	AT
b	COAX® push-in module Xi40-2X2	AU
a	COAX® push-in module Xi40-3X2	AV
d	COAX® push-in module Xi40-2X2, non-return valve	AW
c	COAX® push-in module Xi40-3X2, non-return valve	AX

3. Select connection and function module		P5010 Code
e	Connection module low, G threads	01
f	Connection module high, G threads	02
e	Connection module low, NPSF threads	03
f	Connection module high, NPSF threads	04
	Function AVM™2 NO, G threads	05
	Function AVM™2 NC, G threads	06
	Function AVM™2 NO, NPSF threads	07
	Function AVM™2 NC, NPSF threads	08
	Function CU NC, G threads	09
	Function CU NC, NPSF threads	10
	Function P5010 ES 2/2 NO large hysteresis	11
	Function P5010 ES 2/2 NO small hysteresis	12

AVM™2 NC Failsafe Option - Vacuum stays on if power is lost - E-Stop Condition. For detailed information on AVM™2, CU and ES, see separate datasheets.

Example	Ordering number
Housing, connection \varnothing 10 mm Pi48-2X1, Connection module, low G threads	P5010 00 AI 01

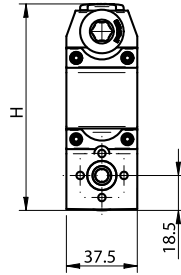
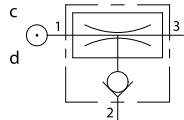
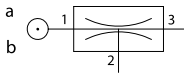

		H
x1	e	50,5
x1	f	66,2
x2	e	93,5
x2	f	109,2

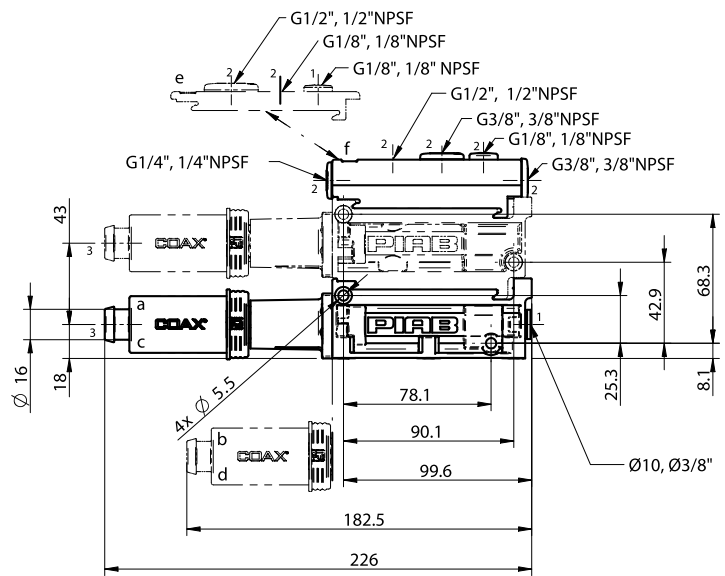

Ordering information, accessories

Description	Art. No.
Common feed adapter \varnothing 10 mm P5010	0117762
Mounting rail DIN P5010	0117763
Mounting rail x1 P5010	0118209
Mounting rail x2 P5010	0118208
Vacuum gauge 100 -kPa	0112531

Vacuum gauge recommended with high connection modules (02/04)